

## DRAWING MANUAL PROCLIP SYSTEM

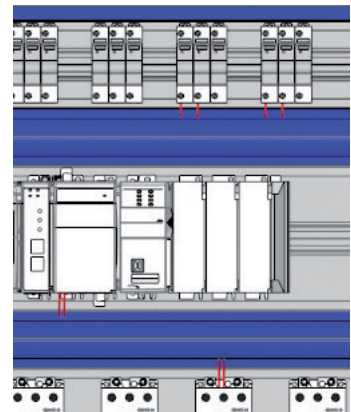

## Table of Contents Drawing Manual Proclip

<b>1.</b>	<b>Frame</b> .....	<b>3</b>
1.1	Enclosure or box with mounting studs.....	3
1.1.1	Calculation of the pillar length.....	3
1.1.2	Calculation of the profile length.....	4
1.2	Modular enclosure with framing.....	4
1.2.1	Calculation of the pillar length.....	5
1.2.2	Calculation of the profile length.....	5
1.3	Enclosure with Unistrut or Non-conventional mounting .....	
1.3.1	Calculation of the pillar length.....	5
1.3.2	Calculation of the profile length.....	6
<b>2.</b>	<b>Profile selection</b> .....	<b>6</b>
2.1	Profile selection for DIN rail mountable components.....	7
2.2	Profile selection for screw mount components.....	7-9
<b>3.</b>	<b>Depth selection EM45 or EM80</b> .....	<b>10</b>
<b>4.</b>	<b>Cover selection CPF's</b> .....	<b>11</b>
<b>5.</b>	<b>Assembly example</b> .....	<b>12</b>
5.1	Profiles position on pillars.....	12



240508



E257460

THIS MANUAL IS A GUIDE TO HELP YOU DRAW SATIE PANELS WITH THE PROCLIP SOLUTION. YOU WILL FIND BELOW IMPORTANT INFORMATION TO HELP YOU DEFINE THE PROFILE SELECTION AS WELL AS THEIR LENGTH.

## 1. Frame

### 1.1 Enclosure or box with mounting studs

In order to design the Satie frame and chose the proper length of profile for your cabinet you need to get the horizontal and vertical studs spacing of your enclosure (**Fig. 1 and 2**).

**Vertical studs spacing = V**

**Horizontal studs spacing = H**

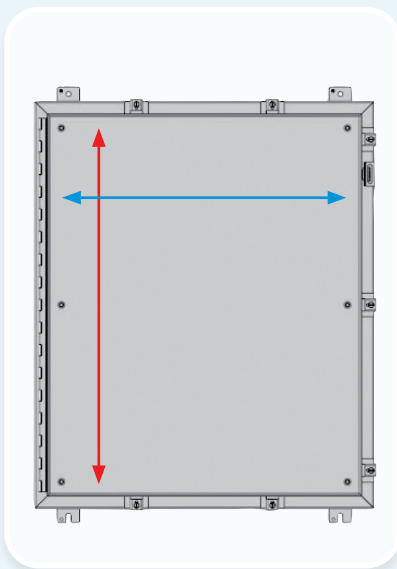

Figure 1

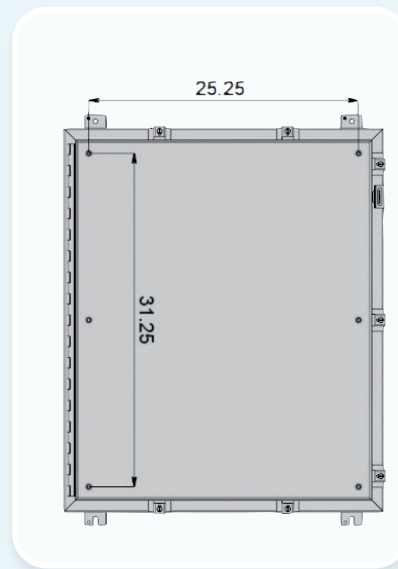

Figure 2

In our example:  
**V**: 31.25 in

#### 1.1.1 Calculation of the pillar length

Pillar length = **V** + 7/8 inch (22mm)

In our case:

Pillar length = 31.25 + 7/8 inch  
= 32.125 in

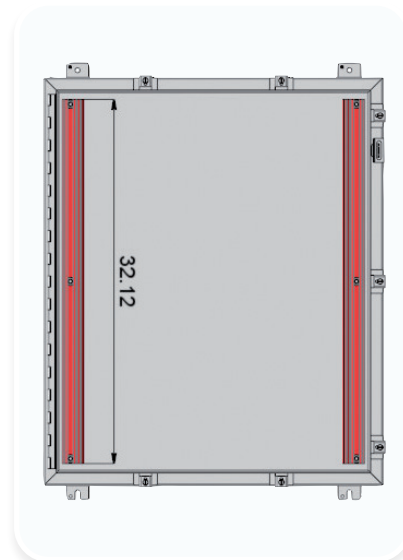

Figure 3

### 1.1.2 Calculation of the profile length

In our case:

$$\begin{aligned} \text{Profile length} &= 25.25 + 1 \text{ inch} \\ &= 26.25 \text{ in} \end{aligned}$$

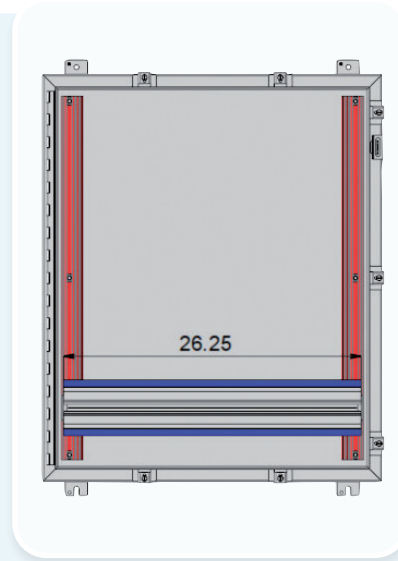

Figure 4

### 1.2 Modular enclosure with framing

For most modular enclosures the Satie frame will be mounted onto the framing of the enclosure using the provided brackets (PDFR or EFD S)

**Vertical outside dimension = V**

**Horizontal outside dimension = H**

In our example:

**V:** 1400 mm    **H:** 600 mm

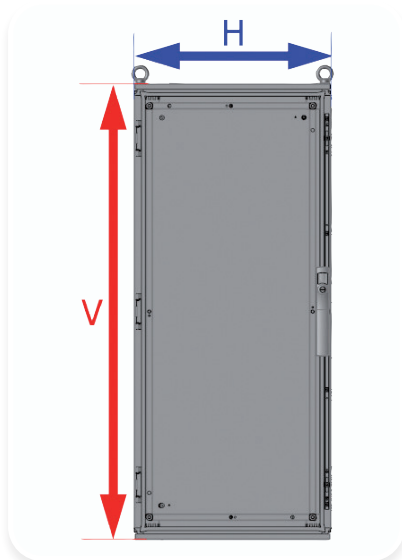

Figure 5.1



Figure 5.2

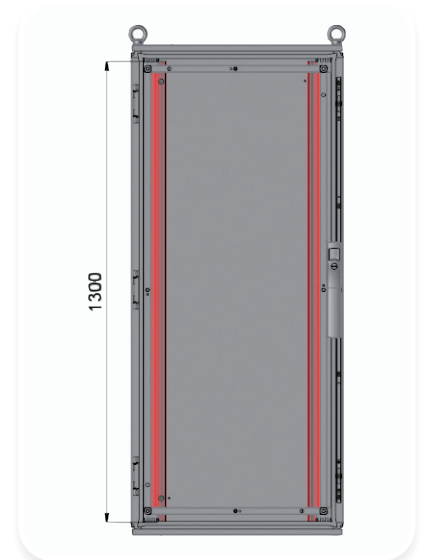

Figure 6



### 1.2.1 Calculation of the pillar length

In our example:

$$\begin{aligned} \text{Pillar length} &= 1400 - 100 \text{ mm} \\ &= 1300 \text{ mm (51.18")} \end{aligned}$$

In our example:

$$\begin{aligned} \text{Profile length} &= 600 - 112 \text{ mm} \\ &= 488 \text{ mm (19.21")} \end{aligned}$$

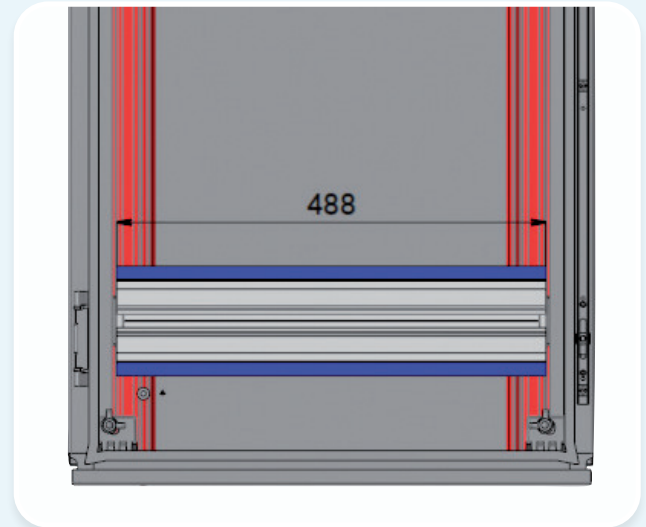

Figure 7

### 1.3 Enclosure with Unistrut or Non-conventional mounting

As a general rule, the outside dimension of the Satie frame shall be smaller or equal to the door opening of the cabinet. The frame is either attached to the Unistrut using the Satie brackets EDFs or using brackets provided by the enclosure manufacture.

**Vertical door opening =  $V_o$**

**Vertical unistrut spacing =  $V_u$**

**Horizontal door opening =  $H_o$**

**Horizontal unistrut spacing =  $H_u$**

#### 1.3.1 Calculation of the pillar length

The pillar length for the Unistrut enclosure is equal or smaller to the opening of the cabinet.

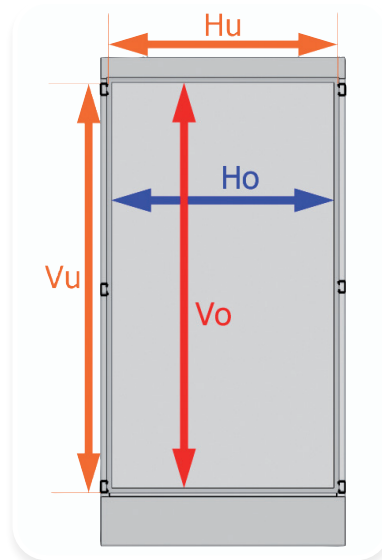

Figure 8

In some occasions the pillar might be higher than the opening. In this case, the pillar will usually be touching the bottom of the enclosure. However, none of the profiles should be attached below the opening dimension as to ensure the panel can be easily installed inside the enclosure without tilting it.

### 1.3.2 Calculation of the profile length

The use of the EDF S to attach to the unistrut allows for a maximum difference between the overall width of the frame and the distance between the unistrut of 34mm (1.34") (**Fig. 9**)

If it is the case the maximum profile length you can have is:

In case

$$Hu \geq Ho + 34\text{mm (1.34")}$$

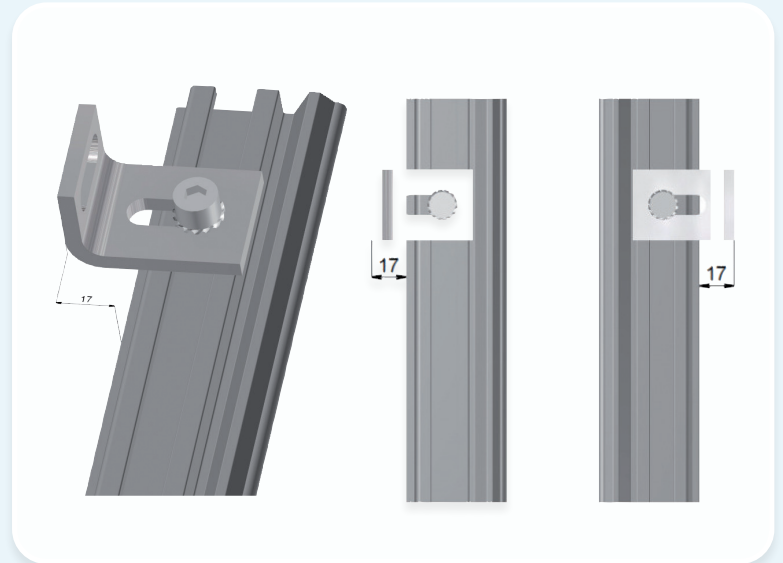

Figure 9

## 2. Profile selection

Height of the profile = **h**

Height of the component = **c**

You have the choice between two types of profiles (PPA and PP) to mount your components. The heights of the profile (**h**) has to be taller than the height of the tallest component (**c**) (when the device is mounted on one profile).

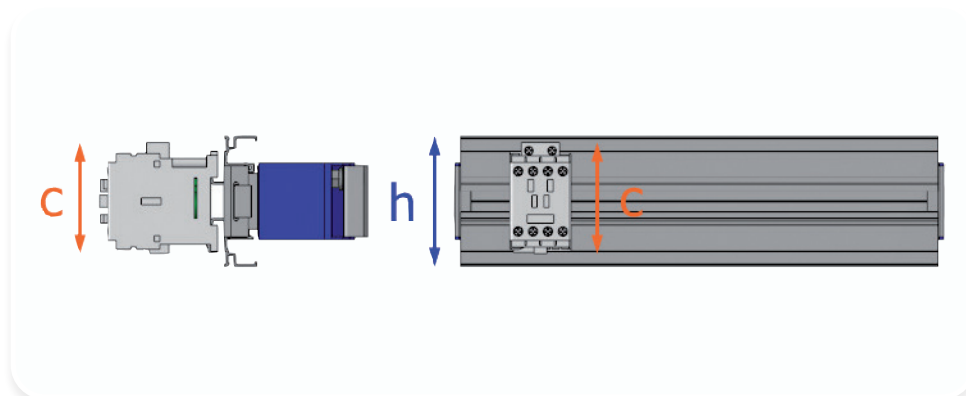

Figure 10

## 2.1 Profile selection for DIN rail mountable components

For Din Rail mountable component the profile can be selected amongst the PPA family (Profile with built in Din rail) (Fig. 11)

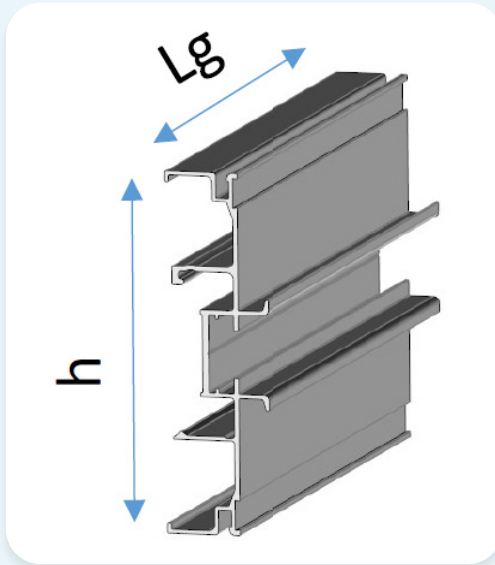

Figure 11

References		h in
PPA	h	imperial
<b>PPA</b>	<b>55</b>	<b>2.16</b>
<b>PPA</b>	<b>75</b>	<b>2.95</b>
<b>PPA</b>	<b>95</b>	<b>3.74</b>
<b>PPA</b>	<b>115</b>	<b>4.53</b>
<b>PPA</b>	<b>135</b>	<b>5.32</b>
<b>PPA</b>	<b>155</b>	<b>6.1</b>

Alternatively a PP profile can be used with the addition of a PS35 snap in Din rail or a DIN35 screw mount Din rail (Fig. 18) for heavier devices.

## 2.2 Profile selection for screw mount components

To fasten panel mount components use the flat profile PP (Fig. 12). These come in different sizes in height (h) and have a groove in the center to accommodate the ER and EA nuts.

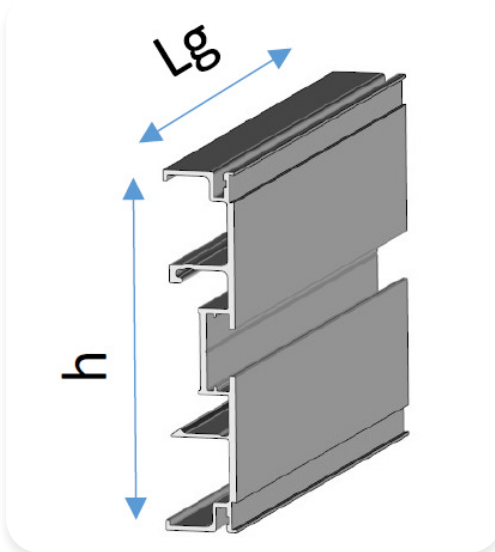

Figure 12

References		h in
PP	h	imperial
<b>PP</b>	<b>55</b>	<b>2.16</b>
<b>PP</b>	<b>75</b>	<b>2.95</b>
<b>PP</b>	<b>95</b>	<b>3.74</b>
<b>PP</b>	<b>115</b>	<b>4.53</b>
<b>PP</b>	<b>135</b>	<b>5.32</b>
<b>PP</b>	<b>155</b>	<b>6.1</b>
<b>PP</b>	<b>175</b>	<b>6.89</b>

The screw mount components can be mounted in between two profiles using the rectangular nut ER or EA. **(Fig.13 and 14).**

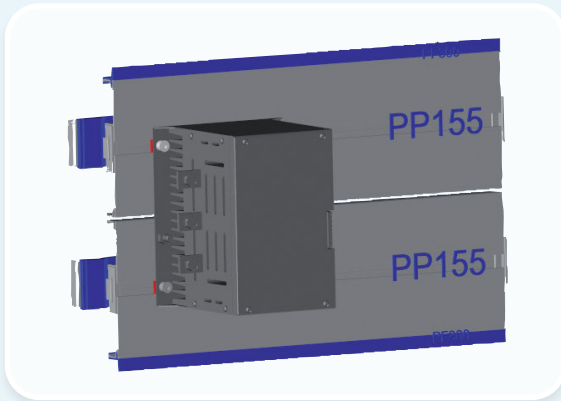

Figure 13

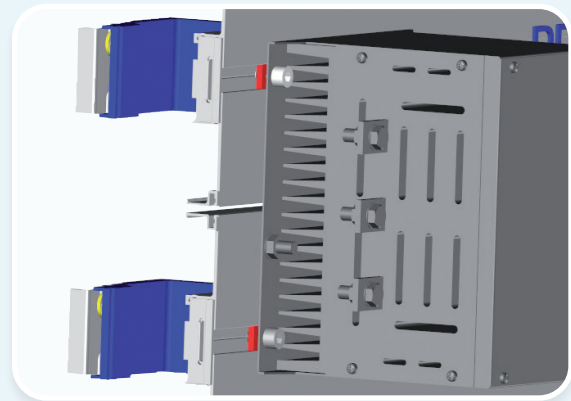

Figure 14

They can also be mounted directly on the profile by drilling and tapping the bottom mounting **(Fig. 15 and 16).**

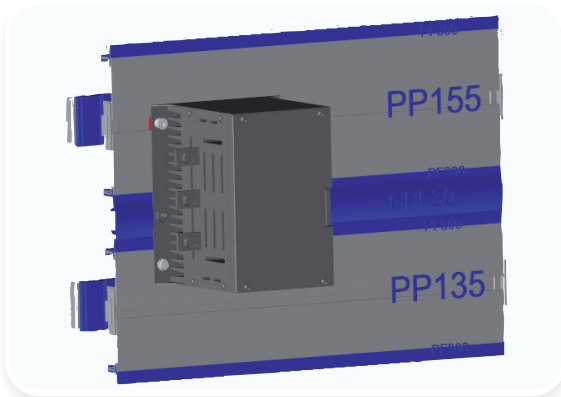

Figure 15

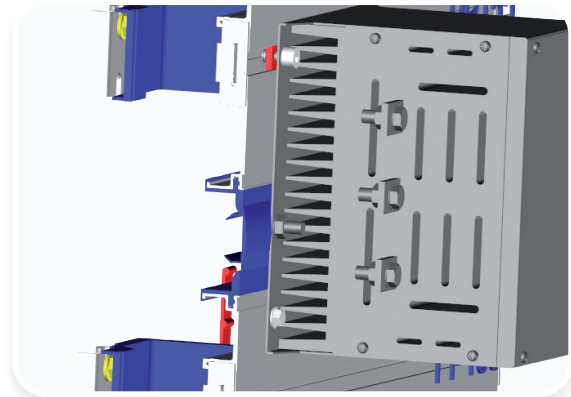

Figure 16

A snap in Din rail PS35 can be snapped into the PP profile to extended the flexibility **(Fig. 17)** and allow to mount Din rail and screw mount components on the same profile **(Fig. 19)**. A DIN35 rail will be preferred for heavier devices.

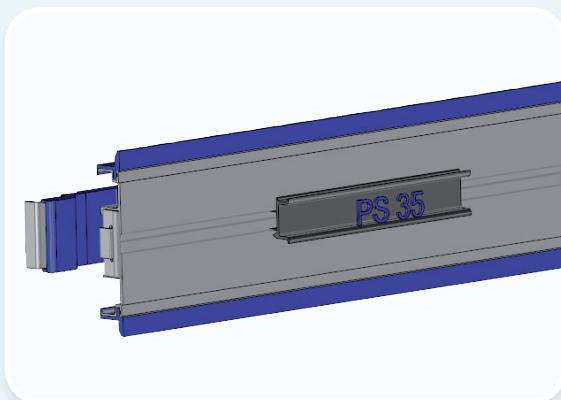
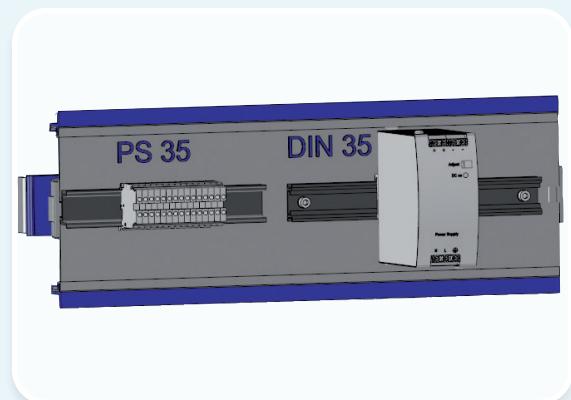

Figure 17





The screw mount devices can also be mounted using the PM50 (**Fig. 18**) mounting profiles. Using a PP Profile the PM50 can be attached in the center (**Fig. 19**) using the ER or EA nuts.

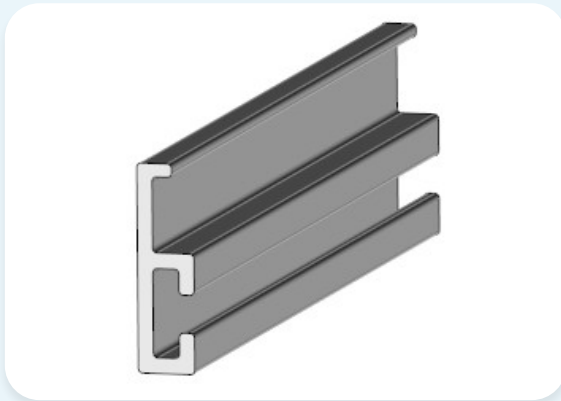

Figure 18

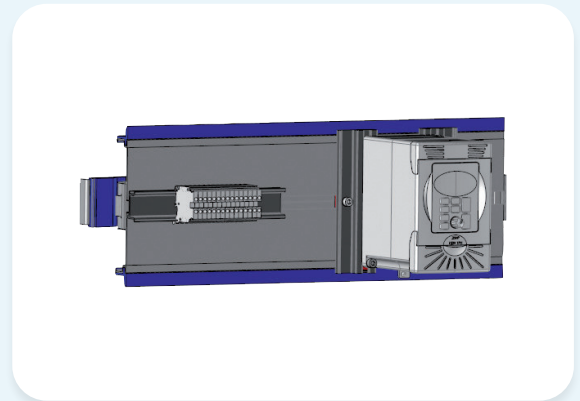

Figure 19

The PM50 can also be attached in between two profiles PP's or PPA's (**Fig 20**).

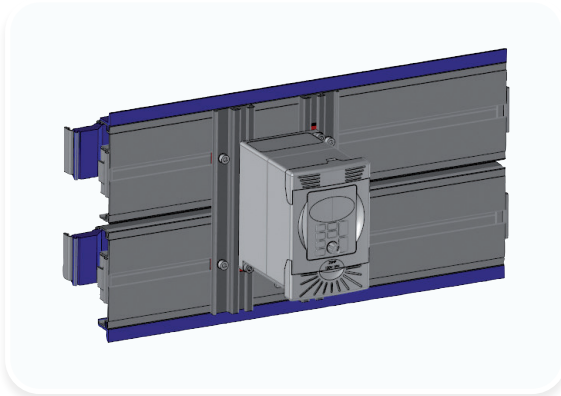

Figure 20

If the depth of the component is an issue to fit the device within the depth of the enclosure the component can be recessed using the PM50 attached to the two main vertical pillars (**Fig. 21**).

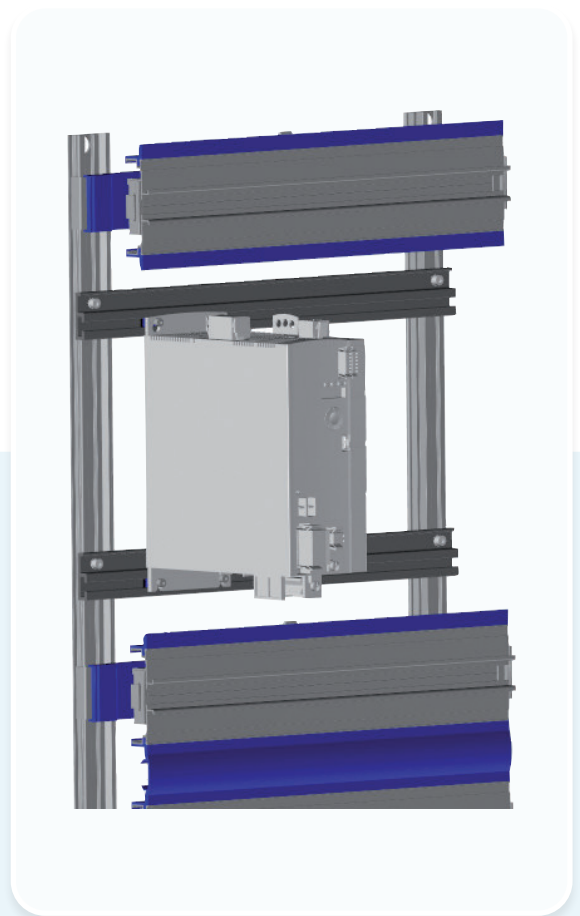

Figure 21

### 3. Depth selection EM45 or EM80

The depth of the frame varies depending on the bracket chosen. For the Proclip version two brackets are available. The EM45 (**Fig. 22**) as well as the EM80 (**Fig. 23**).

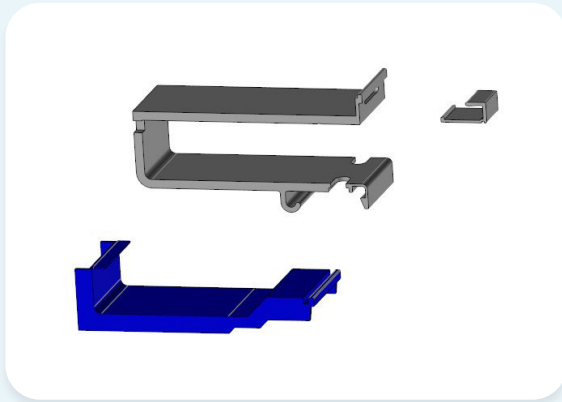

Figure 22

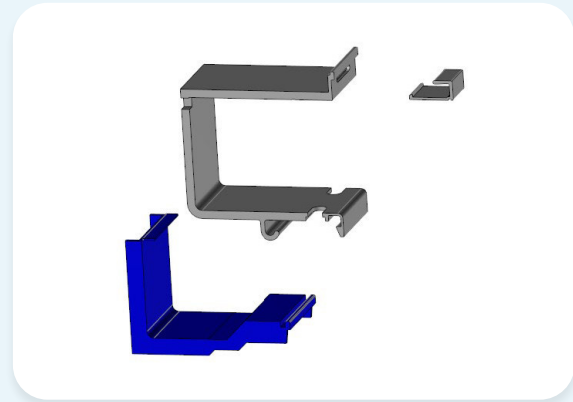

Figure 23

With the combination EM45 + MSF12 the depth of the frame is 70mm (2.8") and with the combination EM80 + MSF12 the depth is 105mm (4.17") (**Fig. 24**).

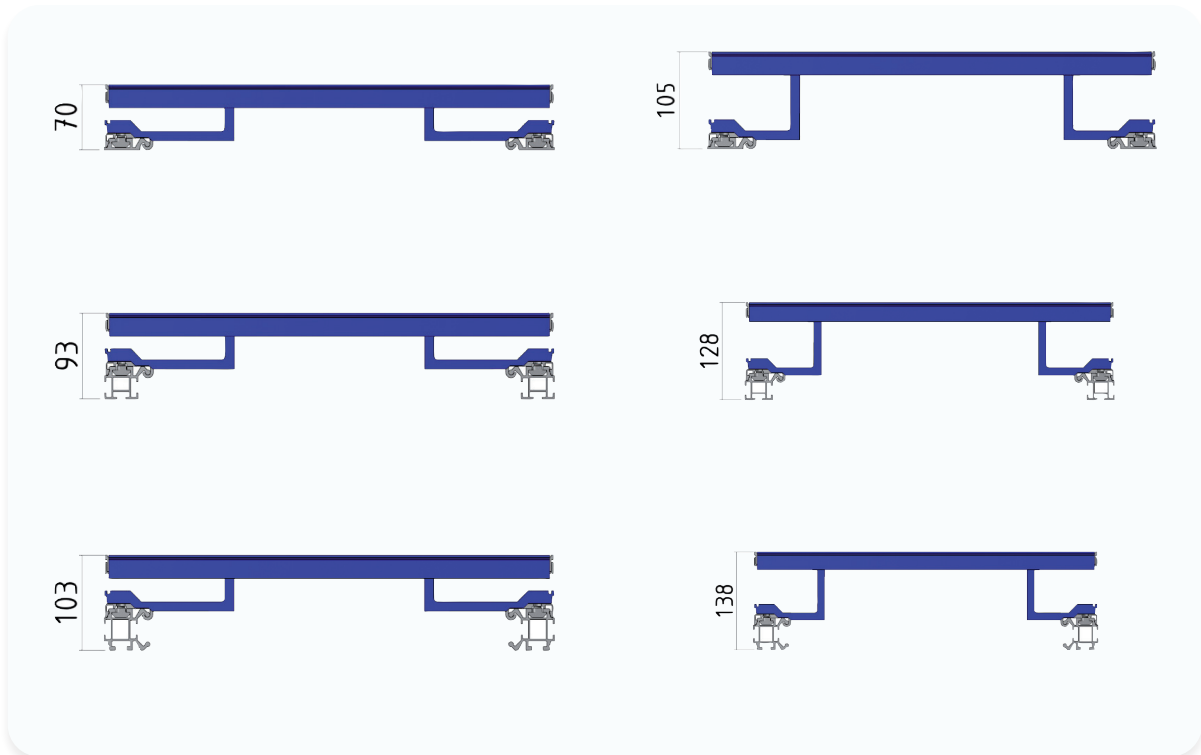

Figure 24

## 4. Cover selection CPF's

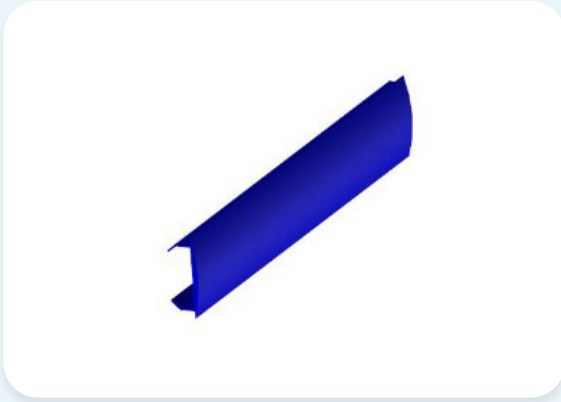

Figure 25

References		h in
CPF	h	imperial
CPF	15	2.16
CPF	20	2.95
CPF	25	3.74
CPF	30	4.53
CPF	35	5.32
CPF	50	6.1

There are 6 covers with different widths available to adjust the distance between the profiles. If you have enough space and for more accessibility the cover size can be increased.

The width of a comb is 15 mm (0.59") and as per **(Fig. 25)** there are 6 different sizes of cover that can be used between two profiles. The space in between two profiles will be as **(Fig. 26)** and **(Fig. 27)**.

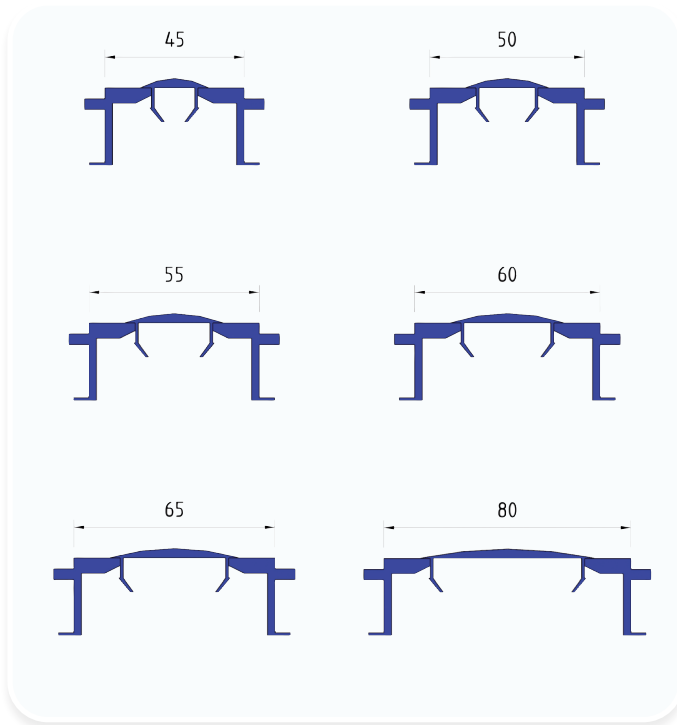

Figure 26

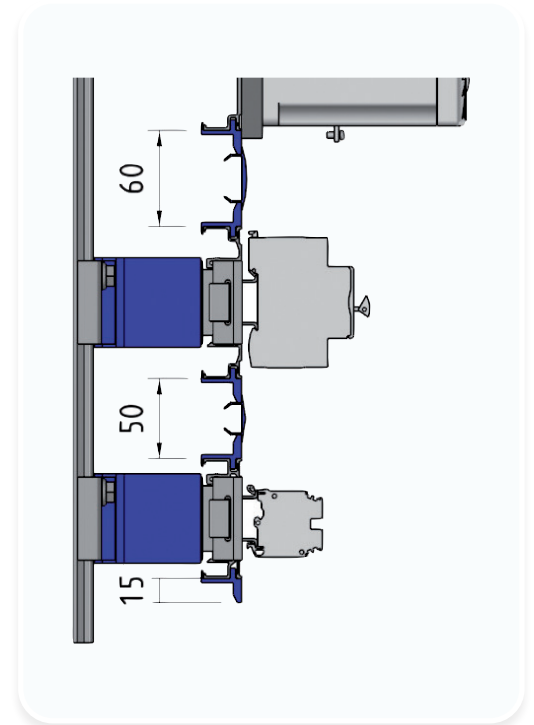

Figure 27

## 5. Assembly example

### 5.1 Profiles position on pillars

By design the overall width of the frame is 12mm (0.48 inches) more than the width of the profile because of the 6mm (6/25 inches) difference between the profile and the pillar on each side (**Fig. 28**).

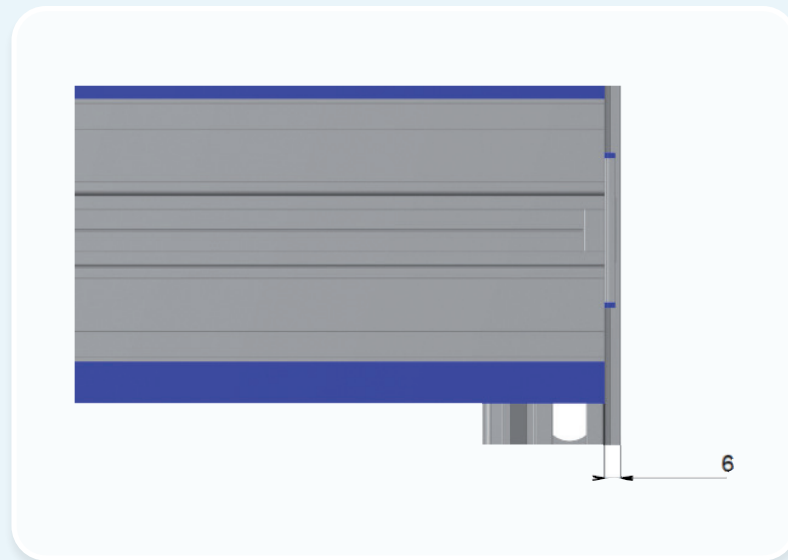

Figure 28

To create the complete assembly you have to start from the top or the bottom with a minimum clearance of  $\frac{3}{4}$  inches (15 mm) (**Fig. 29**) between the top (or bottom) of the pillar and the first comb.

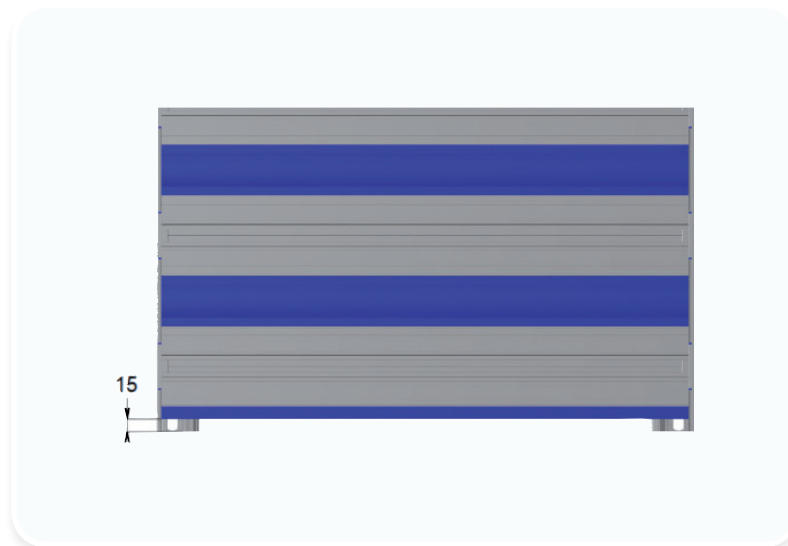

Figure 29

## 5.2 Example of an assembled frame

In order to design the complete assembly select the profile that is taller than the size of the component on the row (Din or Flat). Based on sizing, select the preferred cover. Move on to the next profile until your panel is completed (**Fig. 30**).

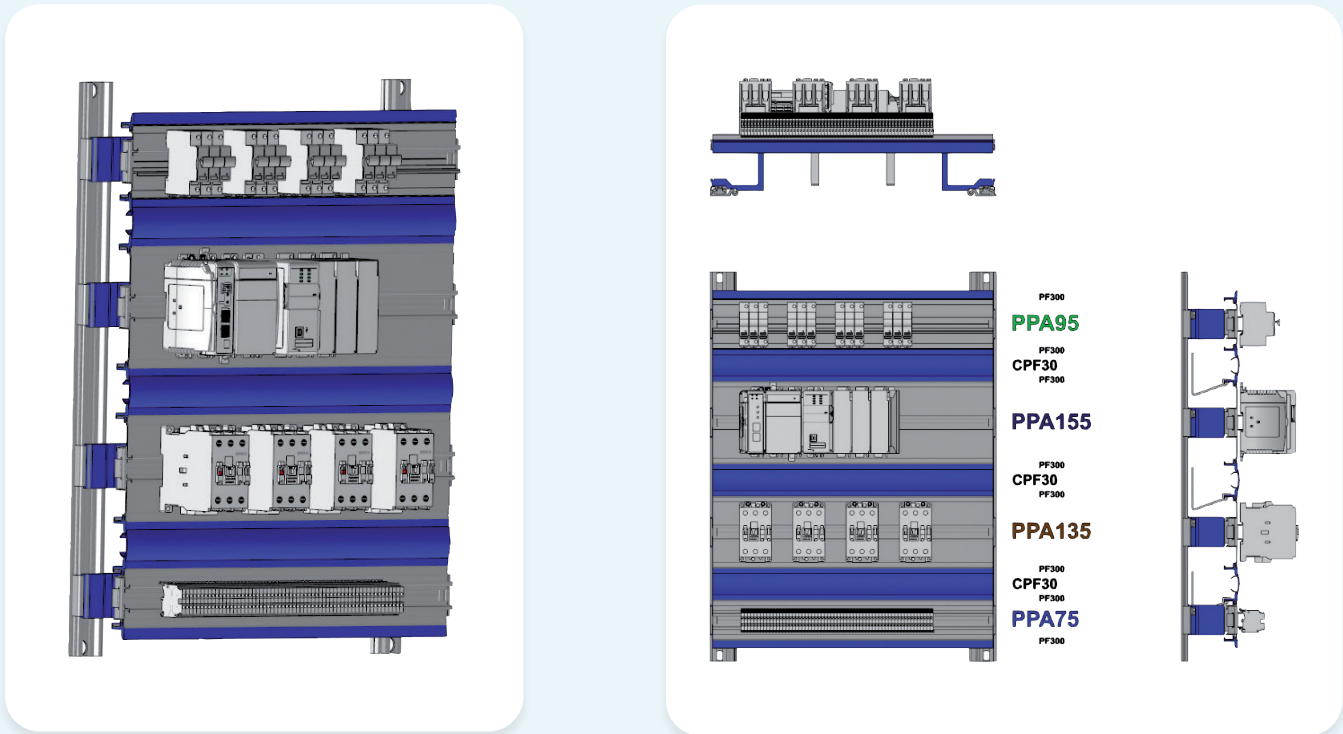

Figure 30

**If you need further assistance please contact us at  
(647) 477-2433 or [info@Satienna.com](mailto:info@Satienna.com)**